

IDE

PAD 800 A Platform

The New Standard in
Active Vibration Isolation
for TEMs and Other
EM Equipment



INTEGRATED DYNAMICS ENGINEERING

PAD 800A Platform

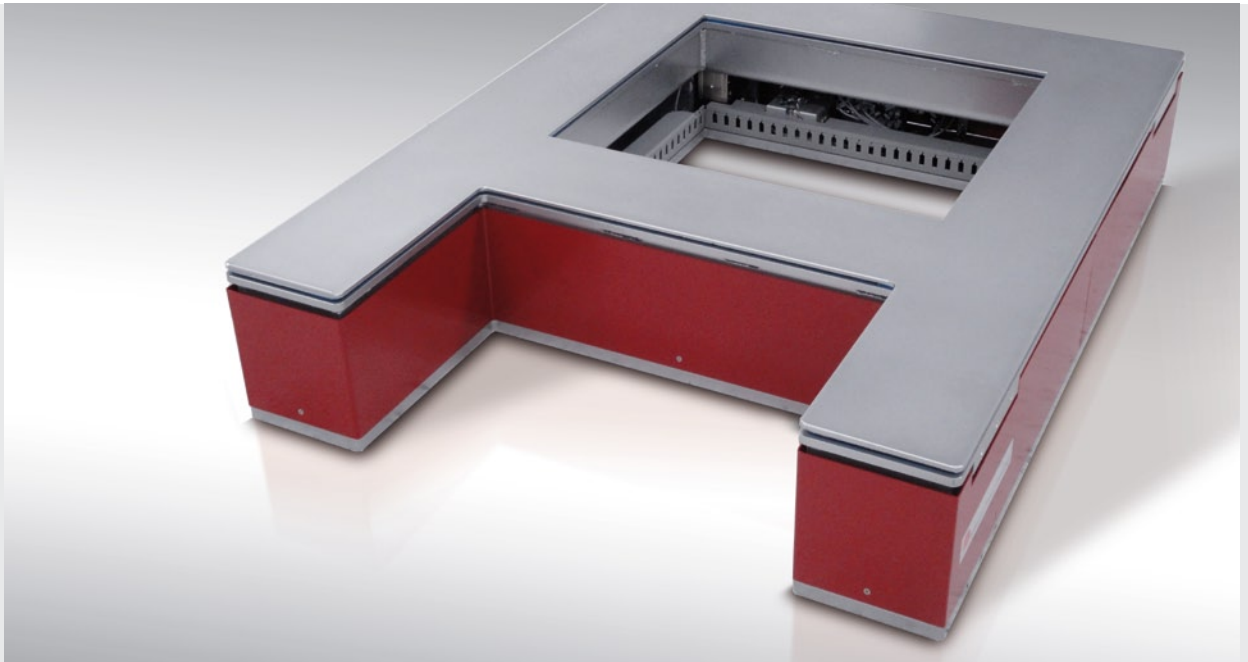

Best price/performance ratio in the market

Built around IDE's field proven PAD 600 vibration isolation system platform, IDE's PAD 800A defines state-of-the-art isolation performance in a new ergonomic design.

The PAD 800A provides the market's highest performance isolation in the most cost effective hardware solution.

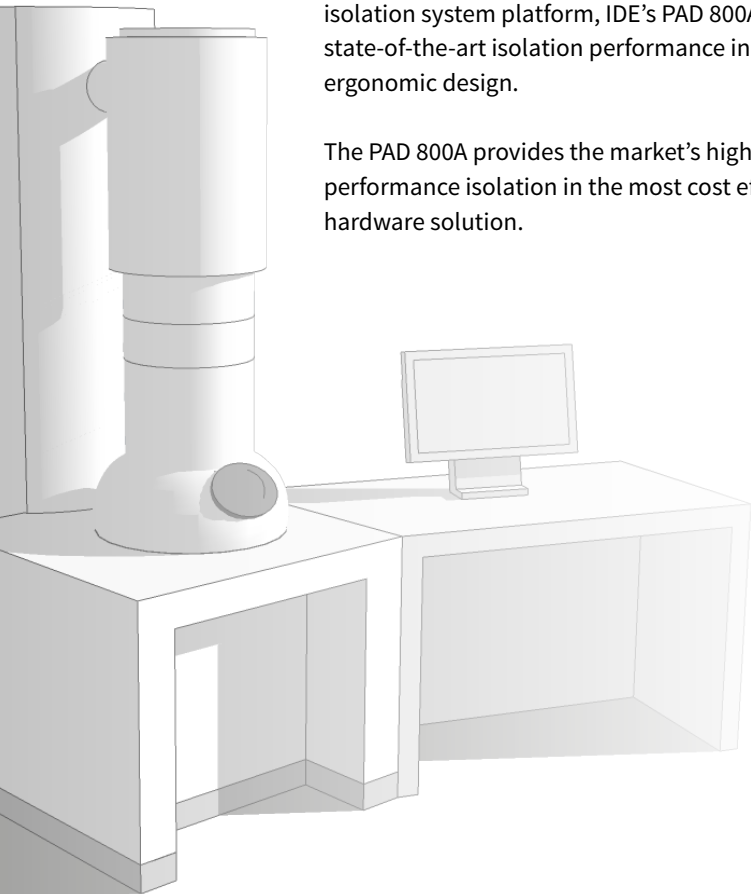

Hybrid Design begins isolation at 0.7 Hz with no air required

The PAD 800A Active Vibration Isolation System Platform exceeds all industry requirements. It is the most cost-effective, six-degrees-of-freedom, active vibration isolation solution supporting the demands of high performance applications.

Enhanced low frequency isolation is achieved through IDE's Floor Motion Feed-Forward feature. This high end performance is standard on every platform.

Unlike conventional active feedback systems, the extraordinary PAD concept makes use of additional floor vibration sensors. The IDE PAD 800A is capable of differentiating between the structural resonances of the payload and floor-induced vibration. These additional sensors deliver critical information about present vibration magnitude, which is vital for improved isolation.

During normal operation, floor and payload vibration are monitored simultaneously. This awareness of the total system transfer function and all levels of vibration enables the PAD's unique IDE Opticon controller to compute correctional forces in both amplitude and phase.

Technical Specifications:

- Transmissibility (see chart)
- Force output 160 N for each horizontal direction
320 N for vertical direction
- Degrees of freedom (D.O.F.) 6
- EMI emission < 0.5 mG (0-100 Hz)
- Power consumption (max.) 0.85 kW
- Power consumption (typ.) 0.4 kW

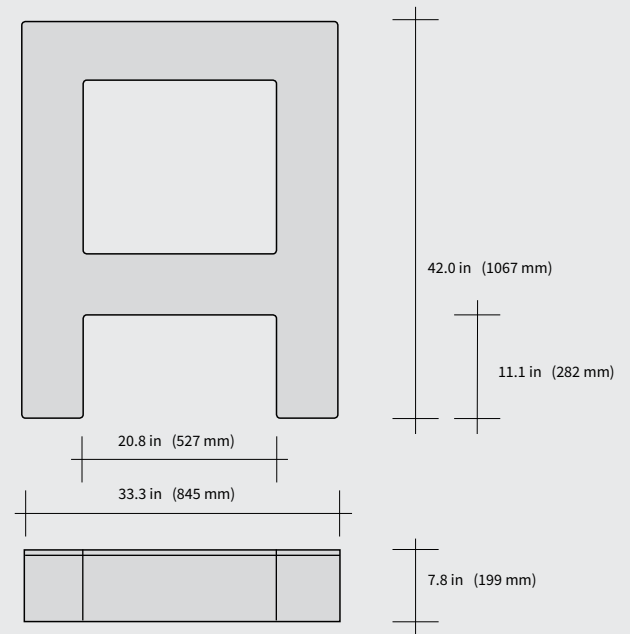

Guaranteed Performance and an IDE Engineer with every platform

Integrated Dynamics Engineering can perform the installation and tune the system to site specific conditions. Other products typically use “auto-tune” functions which isolation based on “average” or typical site environmental conditions. These products deliver only 80% performance.

IDE guarantees 100% performance. An IDE engineer remains on-site until your EM image is optimized and vibration disturbances are mitigated.

Robust Design

IDE continues to meet the growing need for flexible, cost effective, robust, active vibration isolation platforms. The PAD 800A Active Vibration Isolation System consists of an all-metal platform housing with integrated metal spring isolators, linear motors, sensors, and a patented IDE controller.

The all-metal springs eliminate the need for a pneumatic air supply, thereby providing easy portability in a slim, impressively compact design.

The IDE LM Series linear motors provide longer range of motion performance for large disturbances than piezo-based systems without the inherent risk of cracking and premature failures. The IDE PAD 600 and 800 Series Active Vibration Platforms have been the market leaders in uptime performance for more than a decade.

New Ergonomic Design for seated EM eyepiece access

The new PAD 800A design incorporates a low profile isolation platform with an ergonomic design for easy accessibility to the microscope while seated. That's IDE engineering experience delivering high performance with comfort in mind.



PAD 800A Platform

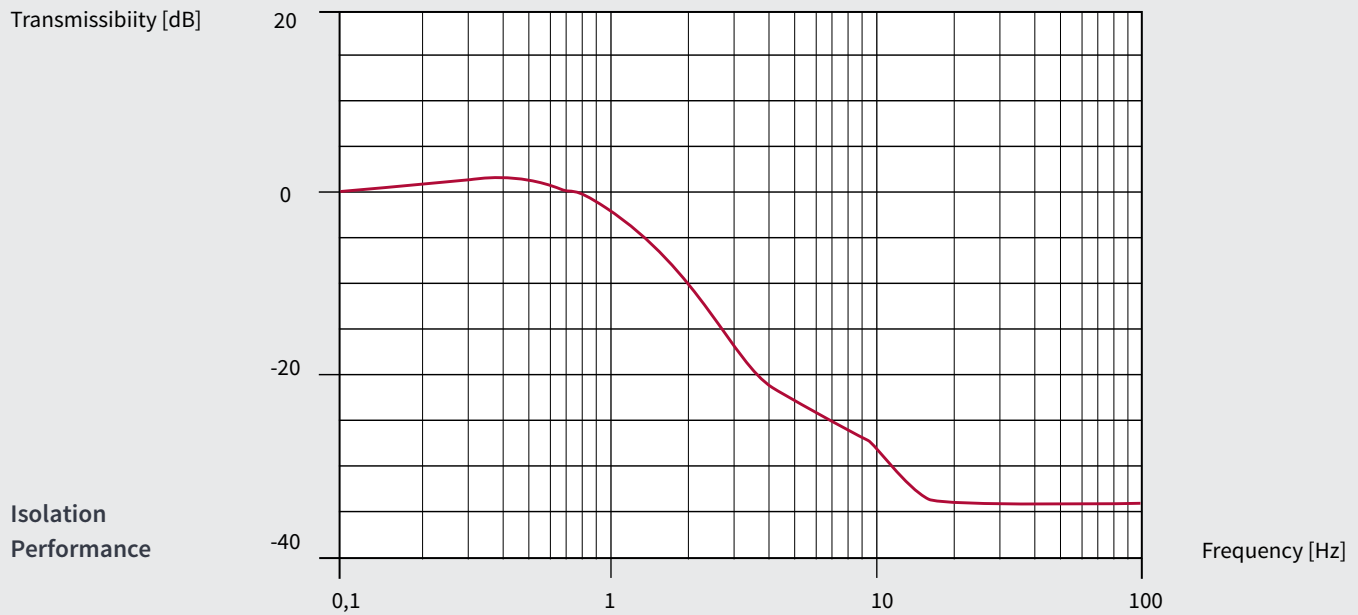

Notes: Typical vertical and horizontal transmissibility curve for PAD 800 with 600 kg granite payload. Actual transmissibility may vary depending on the structural integrity of the payload.

Transmissibility in dB (0dB=1) vs. frequency in Hz.
Measurements conducted without artificial excitation using ambient floor vibration (amplitudes < 10 $\mu\text{m}/\text{sec}$).
Slab on grade conditions.

INTEGRATED DYNAMICS ENGINEERING
Hermannstrasse 9-13
65479 Raunheim, Germany

INTEGRATED DYNAMICS ENGINEERING INC.
68 Mazzeo Drive
Randolph, MA 02368, USA

www.ideworld.com

Phone: +49 6142 94 00-0
info@ideworld.com

Phone: 1 781 326 5700
info@ideworld.com

